



INSTALLATION GUIDE: XUT-3763

Victory Tilt Screen Wall Mounting System

The Victory Tilt Screen Wall Mounting System is designed for secure installation of flat screen displays up to 63”.

Warning Statements

	<p>THE WALL STRUCTURE MUST BE CAPABLE OF SUPPORTING AT LEAST A MINIMUM WEIGHT OF 350 LBS. IF NOT, THE WALL MUST BE REINFORCED. PROPER INSTALLATION PROCEDURE BY A QUALIFIED SERVICE TECHNICIAN, AS OUTLINED IN THE INSTALLATION INSTRUCTIONS, MUST BE ADHERED TO. FAILURE TO DO SO COULD RESULT IN SERIOUS PERSONAL INJURY, OR EVEN DEATH. DO NOT PLACE A UNIT WEIGHING MORE THAN 175LBS. ON THIS MOUNT.</p>
	<p>SAFETY MEASURES MUST BE PRACTICED AT ALL TIMES DURING THE INSTALLATION OF THIS PRODUCT. USE PROPER SAFETY GEAR AND TOOLS FOR THE INSTALLATION PROCEDURE TO PREVENT PERSONAL INJURY.</p>
	<p>PRIOR TO THE INSTALLATION OF THIS PRODUCT, THE INSTALLATION INSTRUCTIONS SHOULD BE READ AND COMPLETELY UNDERSTOOD. THE INSTALLATION INSTRUCTIONS MUST BE READ TO PREVENT PERSONAL INJURY AND PROPERTY DAMAGE. KEEP THESE INSTALLATION INSTRUCTIONS IN AN EASILY ACCESSIBLE LOCATION FOR FUTURE REFERENCE.</p>
	<p>A secure structure must support the weight, or load, of the display. When mounting to a wall that contains wooden studs, dead center of the wooden stud must be confirmed prior to installation.</p>
	<p>Do not install on a structure that is prone to vibration, movement or chance of impact. Failure to do so could result in damage to the display and/or damage to the mounting surface.</p>
	<p>Do not install near heater, fireplace, direct sunlight, air conditioning or any other source of direct heat energy. Failure to do so may result in damage to the display and could increase the risk of fire.</p>
	<p>At least two qualified people should perform the installation procedure. Injury and/or damage can result from dropping or mishandling the display.</p>
	<p>Recommended mounting surfaces: wooden studs and solid-flat concrete. If the mount is to be installed on any surface other than wooden studs, use suitable hardware (which is commercially available).</p>
	<p>Contact Victory Mounts with any technical/installation questions.</p>

Included Hardware		
Universal Washer (Qty 8)		3” Lag Bolts (Qty 6)
Flat Washers (Qty 6)		Note To correctly determine your hardware, please refer to the hardware list below.

Tool List

- Phillips Head Screw Driver
- Electronic Stud Finder
- 1/2” Socket and Wrench
- Portable Drill
- Masonry Bit for Concrete Installation
- 1/4” Drill Bit for Wood Installations
- Level (Commercially Available)

Wood Stud Mounting

1. For secure wood stud mounting, the wall plate must be mounted to two studs at least 16” apart.
2. Use a high-quality electronic stud finder (commercially available) to locate two adjacent studs and mark their locations with a pencil.
3. With the help of an assistant, use a level (commercially available) and position the wall plate against the wall in the desired mounting location.
4. Mark the right, upper and lower and the left (upper and lower), positions of the small horizontal slots that are in alignment with the studs.
5. You should mark four positions total.
6. Next, pre-drill a 1/4” hole in the wall stud at each marked location.

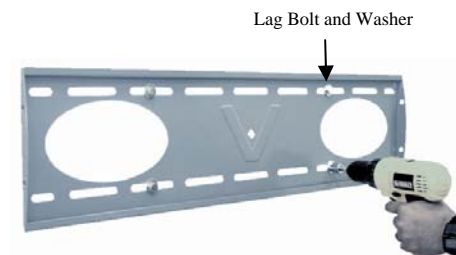

Continued on back page

Continued from front page

7. With the help of an assistant, position the wall plate against the wall and line up the mounting slots with drilled holes.
8. For each location, insert a lag bolt and washer into the wall.
9. Tighten each bolt with an open ended socket wrench by turning clockwise until tight.

STOP Do NOT over-tighten lag bolts when attaching the mount to the wall. Improper installation may result in personal injury or damage to property.

Caution Do not release the wall plate until it is properly mounted and secured to the wall.

Concrete Mounting

Note The concrete anchors must be used for concrete installation. They can be purchased at your local hardware store.

1. Begin by placing the wall plate into position against the wall, using the bubble guide to keep it level.
2. Mark off six holes to be used for securing the mount and place the wall plate aside.
3. Next, drill holes using an electric drill and masonry bit.
4. Insert a concrete anchor into each hole.
5. If necessary, a hammer can be used to lightly tap each anchor into place so that they are flush with the wall.
6. Once all of the anchors are in place, move the wall plate back into position.
7. Attach the nut onto the threaded shaft that is protruding from the wall.
8. Do not tighten until all nuts are in place.

How to Determine Thread Depth

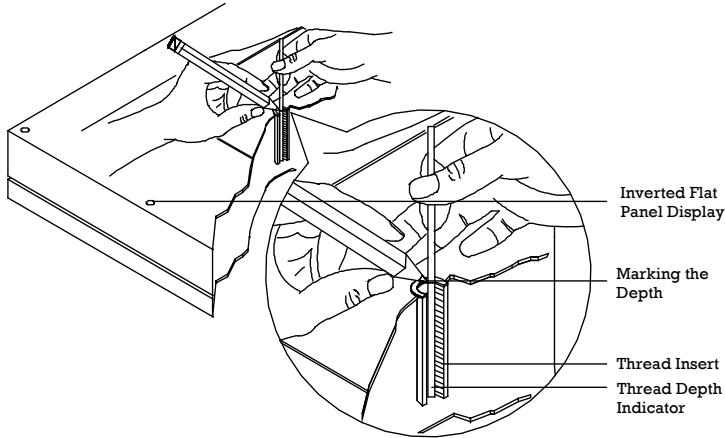

Figure 1



Figure 2

Figure 3

Display Bracket Installation

1. To ensure optimal installation, this kit includes various screws of different diameters and lengths.
2. Place your flat panel screen down on a soft, flat surface, and locate the threaded mounting points that are located on the back of the display.
3. Determine which screw is the correct length by carefully inserting a straw, or toothpick, and mark how deep the mounting point is.
4. If your display has a curved back or a recessed thread mounting point, a spacer must be used.

Note Select the spacer that is closest in depth to the recess to keep your bracket as close to the display as possible.

5. Place the spacer between the mounting bracket and the display.
6. If a smaller screw is being used (M4, M5, or M6) please use a square griplate with each screw for added stability.
7. Attach each bracket to the display by aligning the holes on each bracket, with the threaded inserts on the back panel of your display, inserting the screws through both and turning clockwise until they are fully inserted.
8. Tighten with a Phillips head screw driver.

Final Installation

Caution Two people are required for this step.

STOP MAKE SURE THE LOCKING SCREW IS FLUSH WITH THE LOCKING SCREW TAB BEFORE INSTALLATION.

1. To complete the installation of your new plasma mount, carefully place the flat panel brackets over the upper and lower mounting lips.
2. Use a Phillips head screwdriver to tighten the two (2) security bracket screws (see inset below).

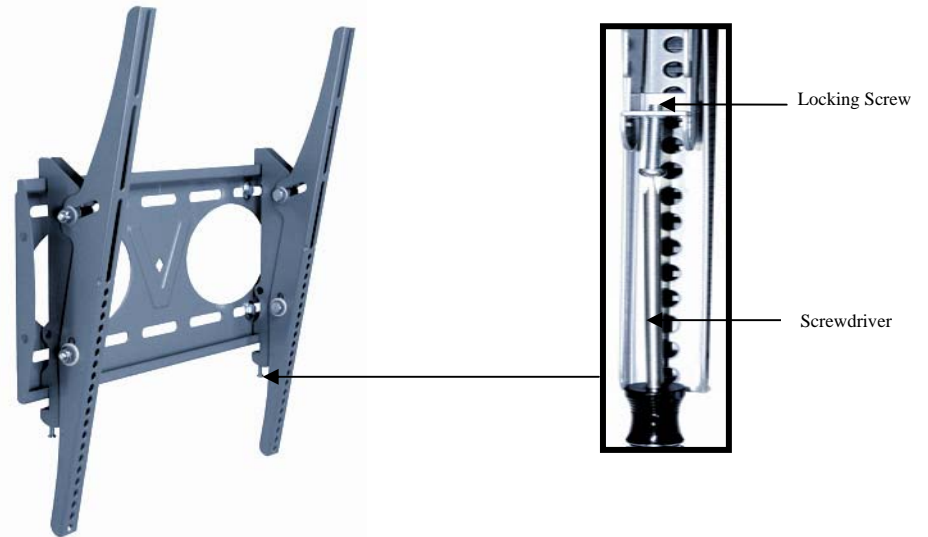
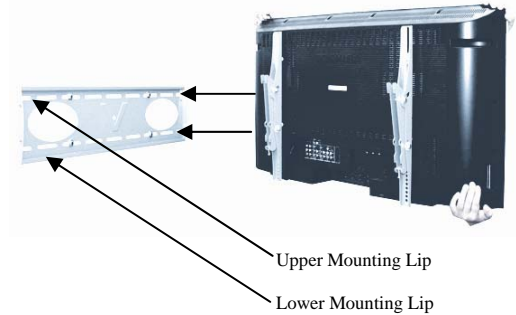

Progressive Marketing Products, Inc.
3130 E. Miraloma Ave.
Anaheim, CA 92806
800-368-9700
victory@mounts.com